

# IMAGE HOME

THERAPEUTICS



# Contents

Pre-work	Safety precaution -----	01
	Parts name -----	04

Installation	Methods of installation -----	05
--------------	-------------------------------	----

Usage and maintenance	Pre-work before massage -----	12
	Features -----	13
	Bluetooth and APP -----	20

Others	Trouble shooting -----	22
	Specifications -----	23

# Safety Precaution

## IMPORTANT SAFETY INSTRUCTIONS

Please read and follow the instructions given below. Failure to comply may result in the risk of burns, fire, electric shock, or injury to persons. Please use a compatible electric outlet to power your massage chair.

### WARNING:

1. Any individual who is pregnant, using a pacemaker, suffers from diabetes, phlebitis, and/or thrombosis or is at an increased risk of developing blood clots due to recent surgery should consult to your physician before using a massaging device or appliance designed for home use.
2. The massage experience should be pleasant and comfortable. Discontinue use and consult with your physician if you feel pain or discomfort.
3. Do not use while sleeping or if you feel drowsy.
4. Do not use the massage chair if your skin is with swollen or inflamed, or if skin eruptions or open wounds are present.
5. This unit has the heating pad under the surface. Those who are not sensitive to heat must be careful when operating.

## SAFETY INSTRUCTIONS

1. Always unplug this appliance from the electrical outlet after use, before cleaning, before installing or removing parts.
2. Do not cover appliance with blankets or other items. Excessive heating can occur and cause fire, electric shock, or injury to persons.
3. Close supervision is necessary when the appliance is used by or near children, disabled persons, or pets. The product is not intended for use by children or persons with reduced physical, sensory or mental capabilities, or lack of experience and knowledge, unless they have been given supervision or instruction on using the appliance by a care giver.
4. Use this appliance only for its intended use as described in this manual. Do not use attachments not recommended by the manufacturer.
5. Please do not use replacement parts from an unauthorized dealer or service provider.
6. Never operate this appliance if it has a damaged cord or plug, if it is not working properly, if it has been damaged, or has come in contact with water. Return the appliance to the manufacturer for examination and repair.
7. Do not unplug the appliance by pulling on the power cord. To disconnect, turn power switch to off position, then remove plug from the outlet. Please do not use wet hands to unplug.
8. Keep the cord away from heated surfaces.
9. Never operate the appliance with the air openings blocked. Keep the air openings free of lint, hair, or other objects.
10. Never drop or insert any object into any opening.
11. Do not use outdoors.
12. Do not operate where aerosol spray products are being used or where oxygen is being administered.
13. Do not stand on or in the appliance. Please do not stand in, climb on, jump on, or sit on the leg rest portion of the massage chair. Use only while seated.
14. Please do not sit on the armrest or the backrest part of the massage chair. The machine may tip and cause bodily harm if excessive weight is applied.

## Safety Precaution

15. Temperatures sufficiently high to cause burns may occur regardless of the control setting. Do not use heating function on children or persons with reduced physical, sensory or mental capabilities. Do not use heating function on a sleeping or unconscious person. Check skin in contact with the heated surfaces of the appliance frequently to reduce the risk of burns or blisters.

16. Move massage chair only when necessary and always handle with care when moving the backrest and leg rest to prevent damages.

17. Never remove backrest coverings and cushions. Examine the textile coverings and cushions prior to each use. If surface shows any sign of deterioration, such as cracking, peeling, blistering or fraying fabric, please refrain from use and contact customer service.

18. If power outage occurs in the middle of use, please switch the power switch to OFF, and unplug the machine to prevent power surge when electricity returns.

19. Please do not fall asleep during the massage, as reflexes and senses are diminished when unconscious, and may result in bodily harm.

20. Please use tremendous care when adjusting the backrest and leg rest reclining positions, and do not adjust positions when children or pets are near, under, or behind the machine.

### Usage Environment Requirements

1. Please do not use machine in a high humidity or dusty environment to reduce the risk of malfunction or electric shock.

2. Please do not place machine in area of direct sunlight or near heat sources.

3. Do not use when temperature of room exceeds 104°F.

4. Please use massage chair in an uncluttered environment with at least two feet of space around the machine.

5. Place and use massage chair on flat, even, non-slip flooring.

6. The massage chair is intended for personal use in a residential setting, and may not be used for commercial purposes.

7. If room is excessively cold or hot, please adjust the temperature gradually and not abruptly. If the massage chair has been stored in a cold area and is moved into a warm area, please wait one hour before use. Condensation may occur as a result and may cause malfunction.

### Safety Precautions

1. Do not use massage chair in combination with other therapeutic appliances as this may result in ineffectiveness or injury.

2. Do not use massage chair for one hour prior or after dining.

3. Do not use appliance when your hands or body are wet.

4. Do not perform fixed position massage on one spot of your body for more than 5 minutes at one time as this may result in excessive stimulation and may cause negative effects.

5. Do not insert your hand or foot along the paths of the massage rollers during use

6. Stop immediately if you experience any discomfort.

7. Do not use when under the influence of prescription drugs, alcohol, or substances

8. Do not apply massage rollers directly on the head, elbow, joints, or abdomen

9. The massage chair is not intended for self-treatment of medical conditions that should be treated by a qualified healthcare provider.

10. Please consult physician prior to use if you are on medication, have medical conditions, or are not sure whether the massage chair is suitable for you.

# Safety Precaution

## Medical Conditions

Please consult your physician prior to use if you are:

- ◆ Under medical rest.
- ◆ Have spinal disorders, an abnormal spinal condition or have suffered a spinal injury.
- ◆ Have excessive back pain and severe back conditions.
- ◆ Have diabetes, osteoporosis or sensory impairment.
- ◆ Have malignant tumor.
- ◆ Have joint dysfunction such as rheumatism, hammer toe or gout.
- ◆ Have a pacemaker or other electronic/mechanical medical devices in your body.
- ◆ May be pregnant.
- ◆ Have phlebitis or thrombosis.
- ◆ Have an increased risk for blood clots.
- ◆ Recently had surgery.
- ◆ Have surgical pins, screws, or mechanical components in your body.
- ◆ Undergoing chemical treatment.

## CAUTION

Please switch off the main power switch immediately and disconnect the power cord from the electrical outlet if:

- ◆ Water is spilled onto the massage chair.
- ◆ Pain or discomfort during massage is experienced
- ◆ Fabric or cushion is torn and internal components are exposed
- ◆ Unnormal sounds or motions occur during the massage

## REPAIR

Do not remove the plastic back cover of the massage chair. Mishandling of the internal components may result in malfunction or injury.

Do not attempt to service or repair the chair. Work must only be performed by professional and authorized service technicians.

## GROUNDING INSTRUCTION

This product must be grounded. In the event of an electric short-circuit, grounding reduces the risk of electric shock by providing a path of low resistance for the electric current. This product is equipped with a cord having a grounding wire with a grounding plug. The plug must be plugged into an outlet that is properly installed and grounded in compliance with any local codes and ordinances.

## DANGER

Improper use of the grounding plug may result in a risk of electric shock. Check with a qualified electrician if you are in doubt as to whether the product is properly grounded. Do not modify the plug provided with the product, if it will not fit the outlet, have a proper outlet installed by a qualified electrician.

# Name Of Each Component

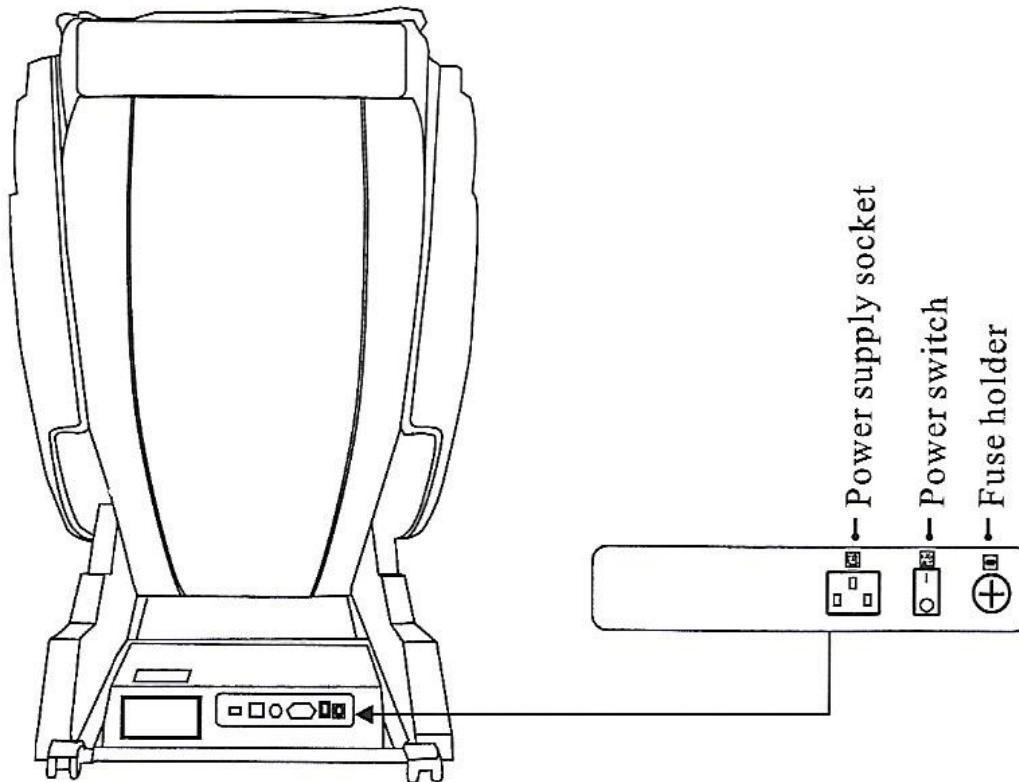
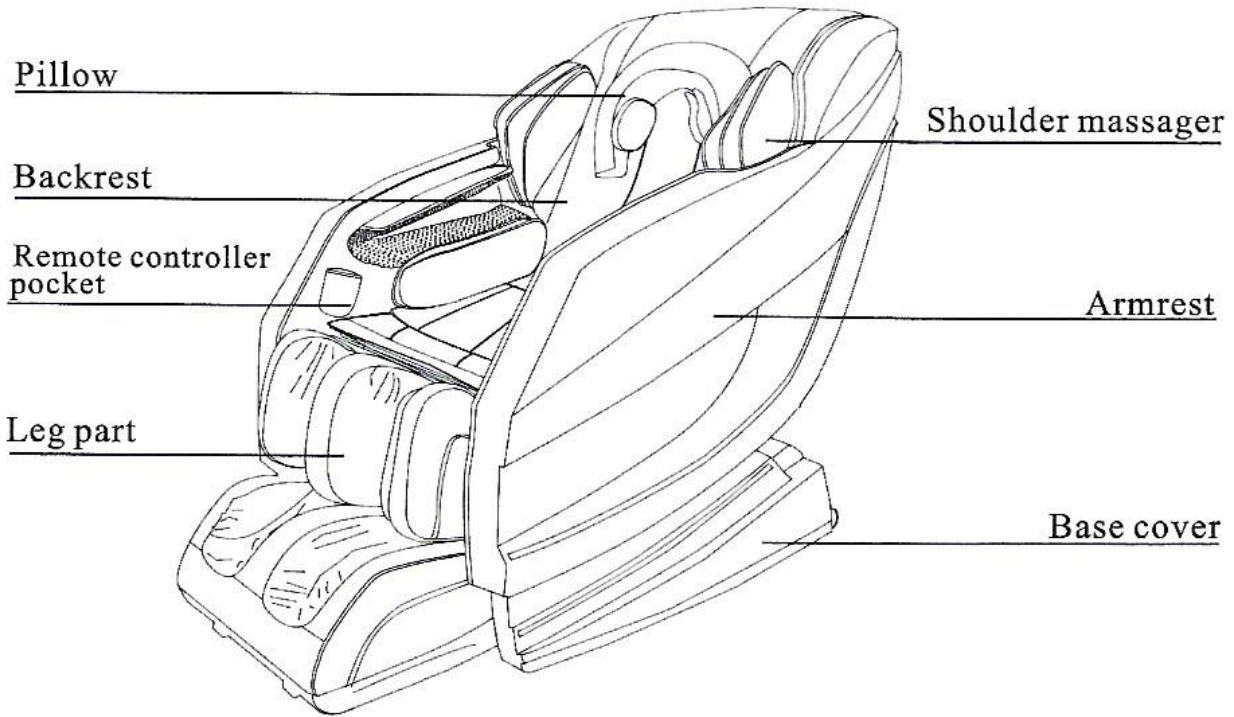

# Method of installation

## Installation(1)

Step1 Unpack the main body box.

Carry out the main body, head pillow and accessory box, when carrying out the main body, due to its heavy weight, we recommend that at least two people work together to carry it out.



Head pillow

Accessory box

Step2: Unpack the armrest box

Take out the armrest and base cover.

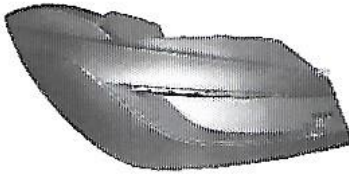

Armrest(Right)



Armrest(Left)

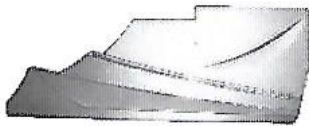

Base cover(Right)



Base cover(Left)

Step 3: Unpack the leg massager box

Carry out the leg massager



Step4: Reset the main body

Connect the power cord, and remote controller, turn on the power switch on the lower back, press the power buttons twice, waiting for about 30 seconds, the main body will go back to the reset position.

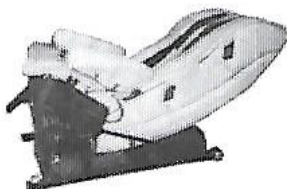

Original position

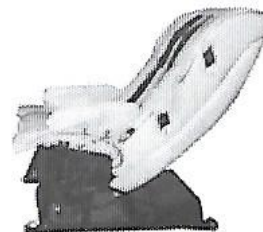

Reset position

## Method of installation

### Installation(2)

Step 5: Install the leg massager lifting rod

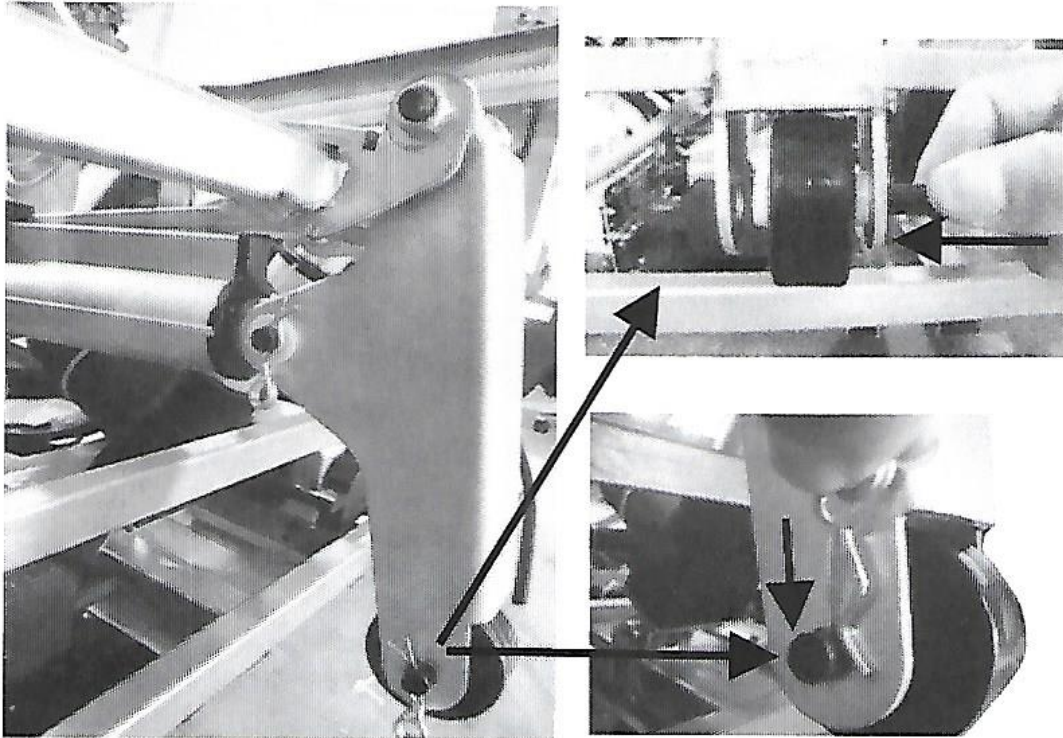

Align the lifting rod with the connector on the main body frame, and fix it with the screw and nut as shown in the upper figure. Connect the lifting rod to the leg massager lifting motor and fix it with the pin and the cotter-pin.

Step 6: Connect the leg part

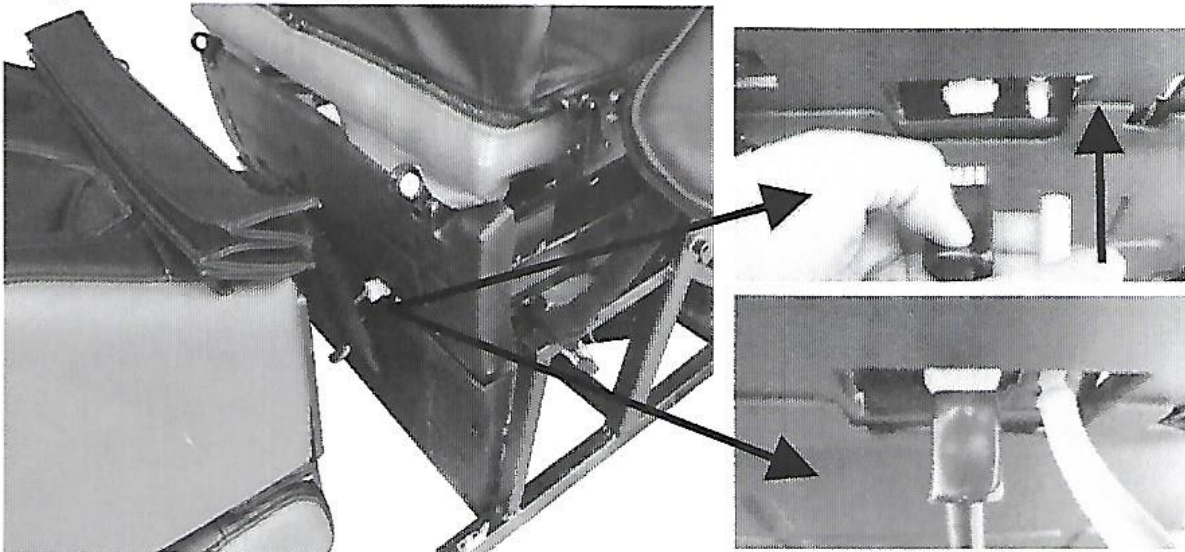

Connect the power cord and air hose to the main body



## Method of installation

### Installation(3)

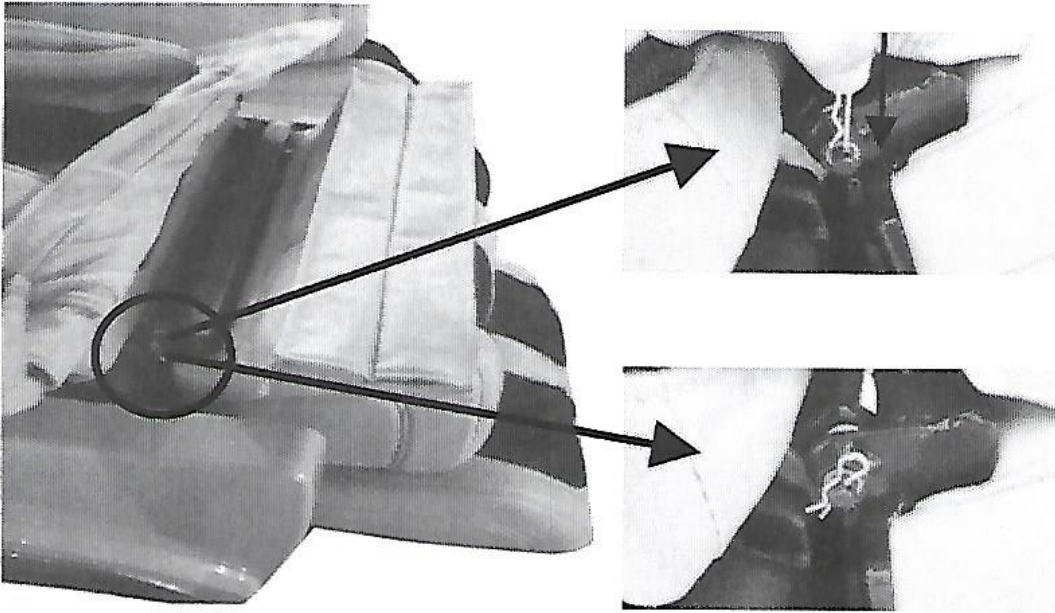

Hang the connector of the leg massager on the hanger of the main body and fix it with pins cotter-pin.

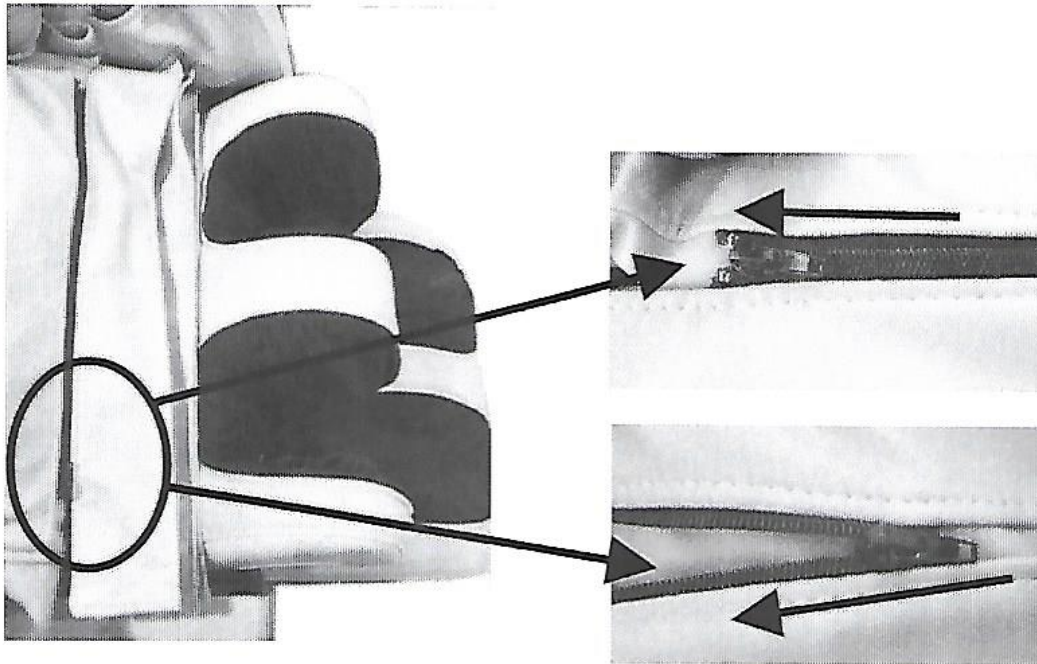

Zip up the zipper between the leg massager and the seat cushion.

## Method of installation

### Installation(4)

Step 7: Install the base cover



Insert the bottom of the base cover to the base frame of the main body.

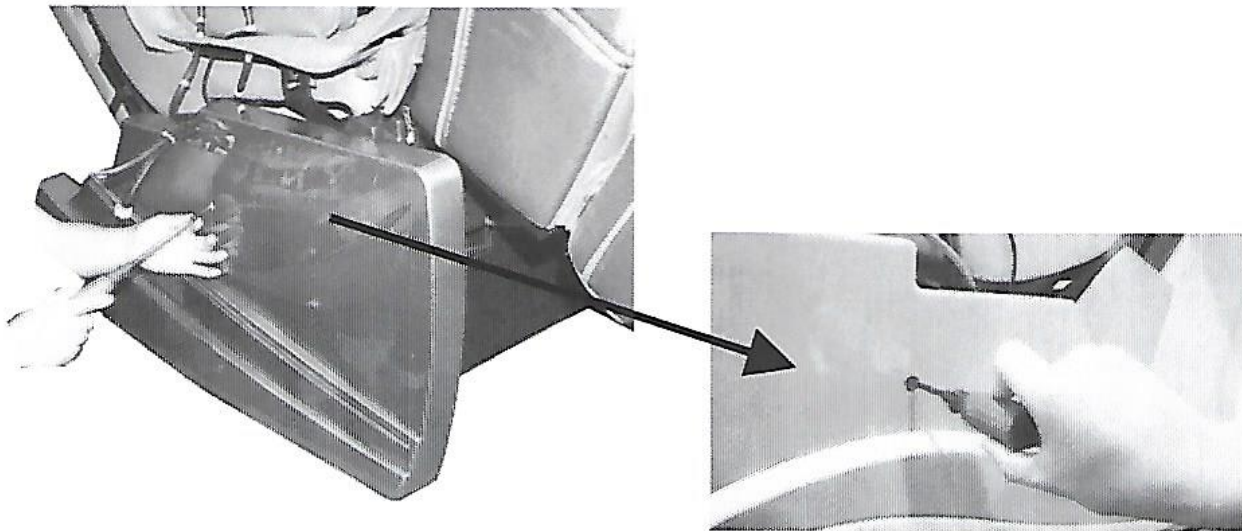

Fix the base cover to the main body with a screw.

## Method of installation

### Installation(5)

Step8: Install the armrest

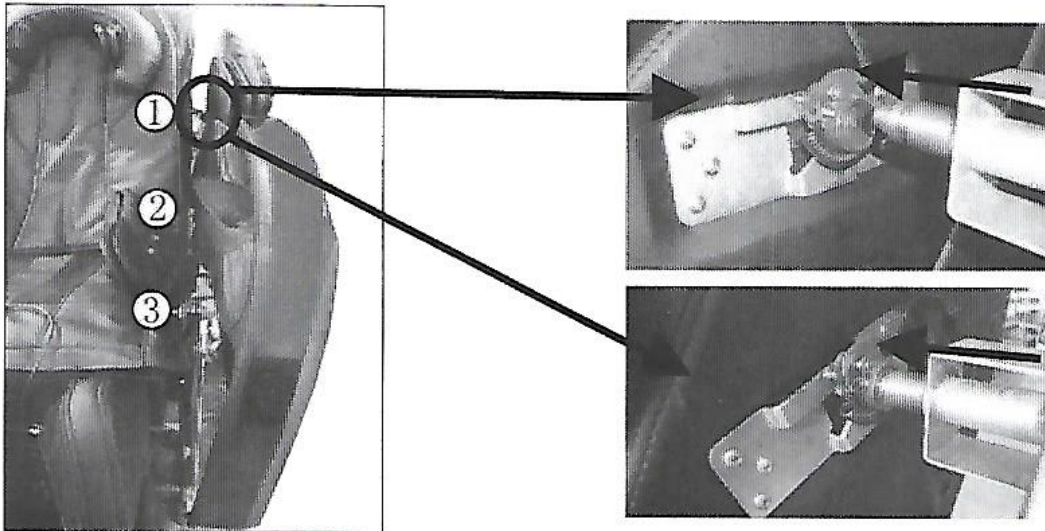

The armrest is connected to the main body via 3 clips. When installing, firstly connect the armrest with the adaptor on the top of the backrest, and press the armrest firmly inwards to lock the clip (lift the front part of the armrest to the vertical position, or the foam between the armrest and the backrest might disable the connection).

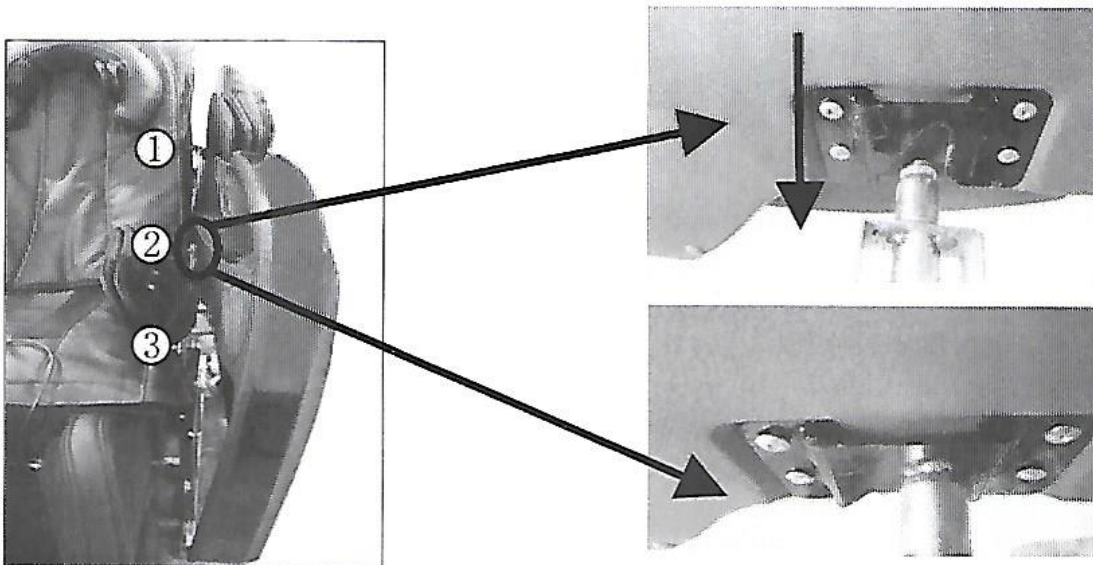

Once the first connector is locked, slowly lift down the armrest, generally, the second clip will automatically lock.

## Method of installation

### Installation(6)

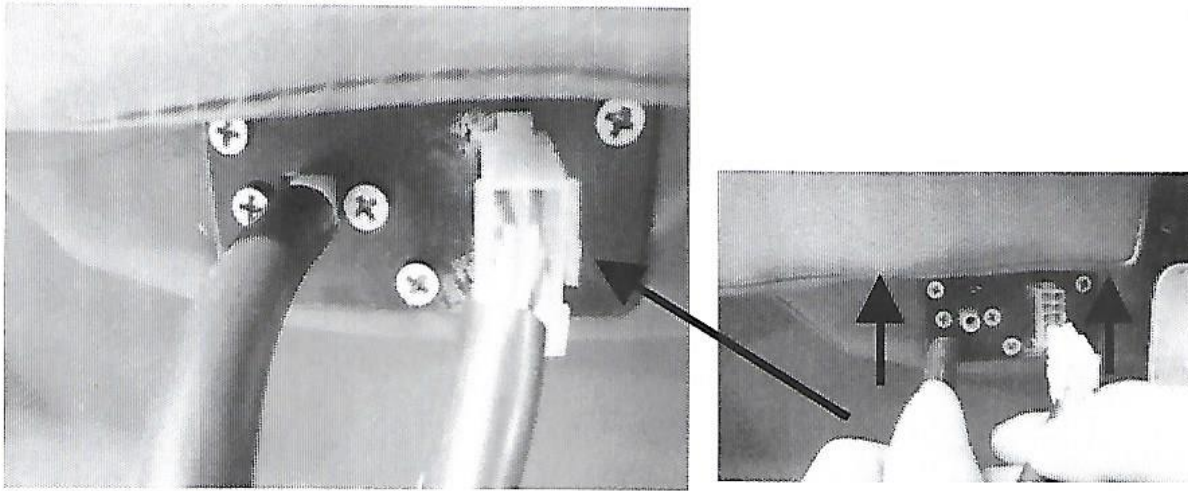

Connect the power plug and air hose which besides the seat to the armrest.

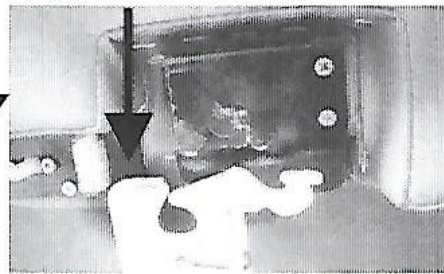
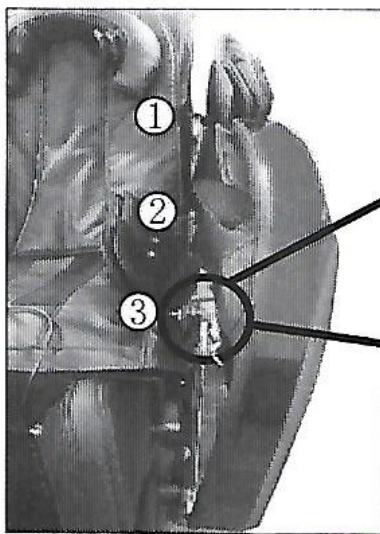

Fully locked

Slowly lift down the armrest so that the third clip aligns with the connector on the front side of the main body. And press the armrest down to lock the third connector. If it is fully locked, you will hear a crisp locking sound. If it cannot be locked, it is usually because the 2nd clip was stuck. To solve this problem, you can try to pull the bottom of the armrest outwards and at the same time press down the front side of the armrest to lock it.



Unlocked

## Method of installation

### Installation(7)

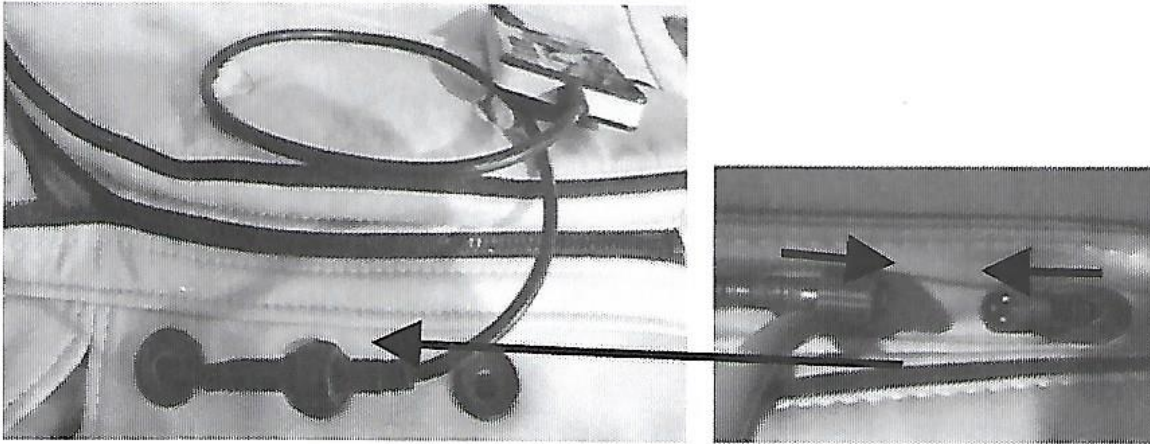

Connect the remote controller to the main body, the connector is located on the left side of the seat. Make sure the connector is inserted in the correct direction, or the remote controller might damage.

Step 9: Install the back cushion

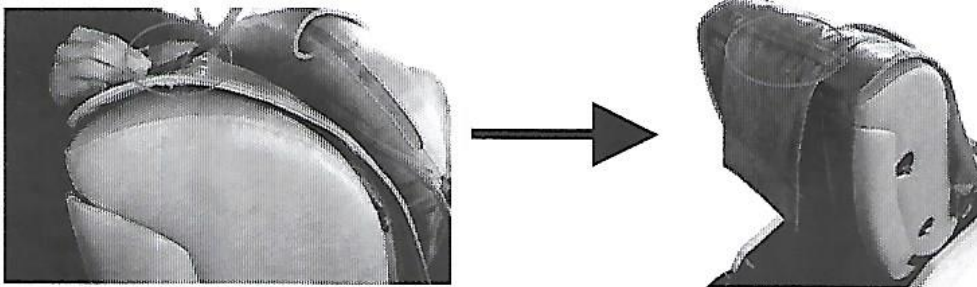

Stick the head cushion to the backrest, please make sure it is under the fixing strip.

## Installation instruction

### SPACE REQUIREMENT

Please remain at least 10cm from the rear of the chair to the wall or any other barrier. And 25cm for the front of the chair.



Before use, make sure that the power cord is in good condition, it shall not be pinched by the chair or any other heavy objects, and shall not be entangled with other items. When the massage chair is working, keep children and pets away from the massage chair so as not to harm them when the massage chair moves up and down.

### METHOD OF MOVING

You can use the wheels in the lower back to move the chair. To do that, we suggest that at least two people work together, one holds the backrest, the other one lift the front side up, then you can move the chair with the wheels.

#### Tips

1. Remove the power cord before moving.
2. If you need to cross a narrow door, remove the armrest fist.
3. Do not use the wheels if the floor is made by wooden or any other material which is easy to damage. In this situation, lift the chair by at least 4 people, and move it.

### ! Attention

Do not move the chair, when there is someone sitting on it.

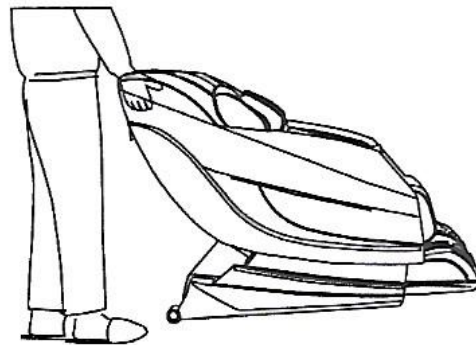

## Confirm and adjust before usage

### New features

**Zero Gravity:** By adjusting the angle of the backrest, seat and leg massager, the chair can offer a zero gravity position, which makes the massage stronger and maximize the relaxation.

**Feet roller:** Equipped with 3 rows of rollers, cover the whole sole, offer artificial human scrape therapy massage from heel to toes.

**Full arm air massage:** Offer an air pressure massage for the full forearm with 12 groups of build in airbags.

**Auto-extending leg massager:** The leg massager can extending/retacking automatically to fit the user's leg length.

**Heat:** Heat the waist, buttocks, calves, and heels

**S&L track:** Up to 130cm L shape back roller track, allows the back roller to massage from head to thigh, S curved back area, make the neck and lower back massage powerful than ever.

**Head massage:** Patented design, offering air massage for the temple, position adjustable according to user's height.

**Bluetooth Connection:** Equipped with Bluetooth chip, the chair can pair with your phone or tablet, allows you to display your favorite music on the chair. You can also operate your massage chair with your Android or iOS device.

**Sliding function:** The backrest will slide forward automatically while the chair is reclining down, which allows you to place the chair closer to the wall, to save space required for the chair.

### Replace the fuse

To replace the fuse, please remove the power cable first, turn off the power switch, use a screw driver to open the fuse holder in the lower back of the chair.

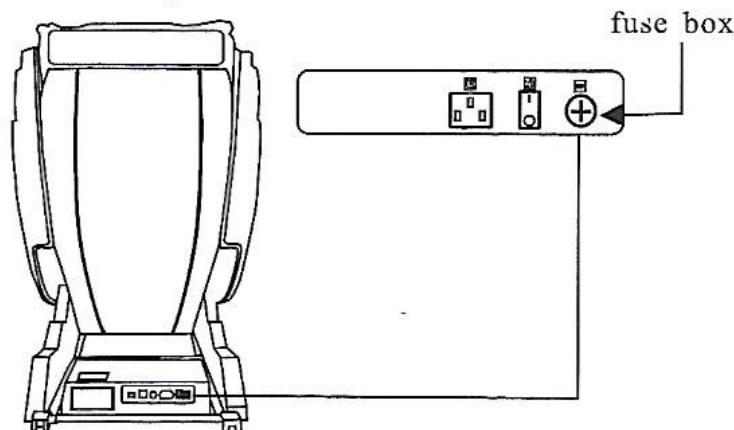

# Remote controller instruction





## Remote controller instruction

### Instruction of the buttons



**Power: Turn on/off the chair**

- ◆ Press this button the chair will start to work (for the first time after the chair connected to power source, you need to press twice to turn on the chair.)
- ◆ When the chair is working, press this button will turn off the chair, and reset its angle.



**Pause**

- ◆ When the chair is working, press this button, all functions will be suspended, press it again, all functions will recover.



**Menu**

- ◆ Press this button to enter the menu if you are in the home screen; if you are in the menu, press this button will switch to home screen



**Adjust shoulder height**

- ◆ The back roller will adjust its travel height according to the user's body height. These two buttons are for adjusting the height set after body scanning, so it could be more accurate.



**Full body program switch**

- ◆ This chair has 6 full body program, you can switch among them by press this button.

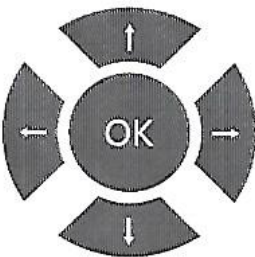

**Direction buttons**

- ◆ Up/down button: In the home screen, if the back roller is in the focus/partial massage mode, press this button can adjust the back roller position; in the menu, press this button to select, and press OK to confirm your selection.
- ◆ Right/Left button: In the home screen, press and hold this button can adjust the leg length; in the menu, press the right button to enter sub-menu; and press left to go back.



**Zero gravity**

- ◆ Press this button to enter the zero gravity position, and the zero icon on the home screen will light up. If you adjust the leg massager or backrest angle after in zero gravity position, the zero icon will turn grey, and the chair will out of zero gravity position.



**Lift up the leg massager**

- ◆ Lift up the leg massager by holding this button. Shot press it will active the leg length scanning process.



**Lift down the leg massager**

- ◆ Lift down the leg massager by holding this button. Shot press it will active the leg length scanning process.



**Lift up the backrest**

- ◆ Lift up the backrest by holding this button.

## Remote controller instruction



Lift down the backrest

- ◆ Lift down the backrest by holding this button.



Heat

- ◆ Turn on/off the heat function of the chair. There is a heat icon in the home screen, it will turn red when the heat is on, and turn grey if it is off.

## Icon and Menu

### ► Auto program

This chair offers 6 full body auto massage program for option, to meet the preference of different users.

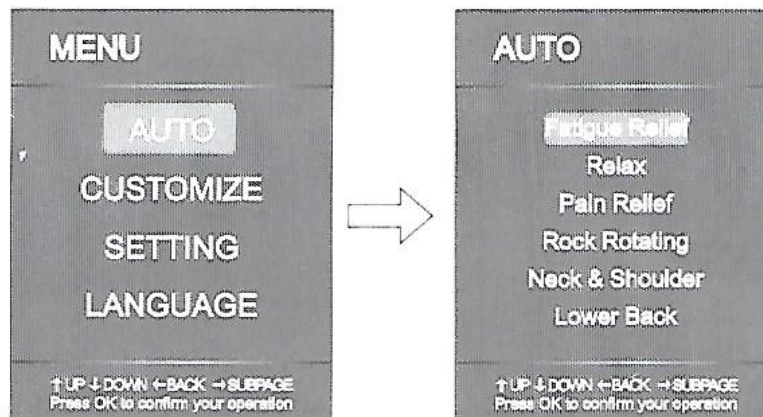

**Fatigue Relief:** This is the default program of the chair, it offers stretch for the legs and back, which helps the user to get recover from fatigue or stress. The chair will automatically switch to this program if the user doesn't perform any operation after booting the chair.

**Relax:** This program is prepared for new users or users who prefer a less intensity massage. The massage experience of this program is softer than others.

**Pain Relief:** This program helps users to relieve pain, stiffness and other discomfort by offering deep massage.

**Rock Rotating:** In addition to the comprehensive body massage, this program helping users to fall asleep quickly through a slow and rhythmic rotation. Designed for those who want to take a short break in the massage chair.

**Neck & Shoulder:** Full body massage program which has a higher massage frequency in the neck and shoulder area.

**Lower back:** Full body massage program which has a higher massage frequency in the lower back area.

# Remote controller instruction

## ► Customize

The customize offers multiple options for adjusting the chair to meet your preferences. Press UP/DOWN arrow to select, and press OK to confirm selection. Press the Left arrow to get back.

### Roller Speed

Adjust the massage speed of the back roller. The back roller speed has 6 levels for option, 1 is the lowest, and 6 is highest.



### Air Intensity

Adjust the air bag intensity of the massage chair. The air bag intensity has 5 levels for option, 1 is the lowest, and 5 is the highest.



### Massage Width

Adjust the massage width of the back roller. The back roller width has 3 options, you can choose according to your body width.



## Remote controller instruction

### Sole roller speed

Adjust the massage speed of the sole rollers. The sole roller speed has 3 levels, and you can also turn it off in this menu.



### Massage method.

The back roller has 6 different massage method, and they will appear alternately in automatic mode. If you want to choose only one method, you can choose under this menu.



### Massage area

Choose the massage area of the back roller. It offers 3 options: Overall allows the back roller to massage from top to bottom; Partial will make the roller going up and down in a certain area; and Focus will keep the roller massage in a certain point.



# Remote controller instruction

## Air bag On/Off

You can either turn on/off all the air bags or a certain area in this menu.

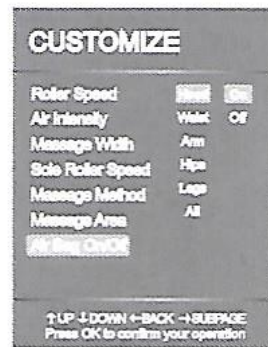
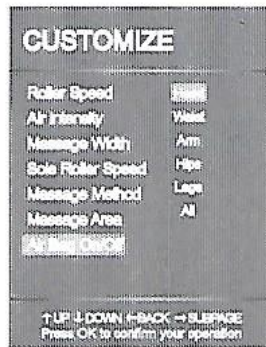

## ► Setting

In the Setting menu, you can set the default massage time for each session. It offers 5 options, from 10 minutes to 60 minutes. We suggest to start with 10 minutes, and be cautious for options over 30 minutes.

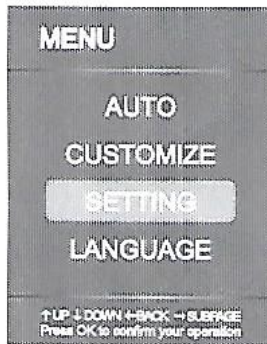

## Tips:

1. In the menu page, if there is no operation within 10 seconds, the screen will switch to the home page automatically.
2. Press “Menu” button for twice to quick switch to the home page.
3. The chair will detecting your shoulder position automatically, anyway, if it is not accurate, you can fine-tune it by holding the shoulder position button in the home page.
4. Press the “Auto” button to quick switch among 6 full body programs.

Each time you turn on the chair, it will start with a body scan process. All functions will be locked during it. If you find that the chair is unable to operate, please check if it is under this process.

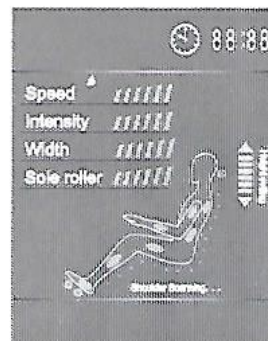

## Bluetooth and APP

### Bluetooth Connection

▶ This chair has equipped with a Bluetooth chip and an Audio system. It allows you to display your favorite music via any Bluetooth Enabled device. To do that, please turn on the Bluetooth function of your device, pair with the device named “Massager”.

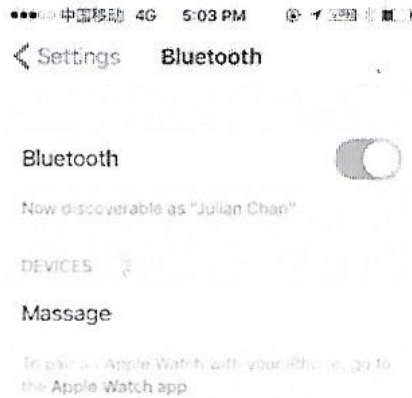

▶ We also made an App which allows you to control the chair via your smart device. The App is available on both iOS and Android. You can scan the QR code below to download it.



iOS



Android

▶ For iOS users, you can search for “Massage chair remote” in the App store, then select the app as the right picture shows.



## Bluetooth and APP

### App Operation Guide

► To operate your massage chair with the App, please firstly pair with the chair in your device's Setting-Bluetooth menu; then open the App, and click on the Bluetooth icon in the home screen, and pair with the device again. After the connection is settled, you will be able to control the chair with all the buttons.

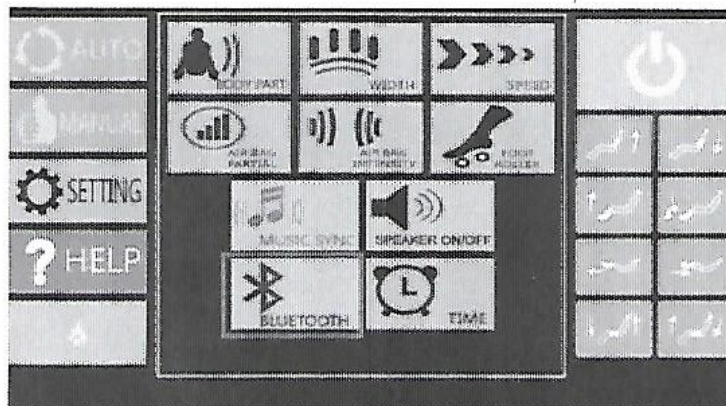

Click the Bluetooth icon

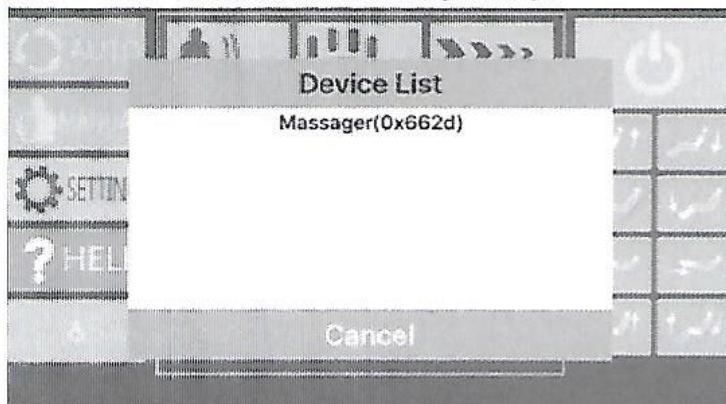

Pair with the "Massager" again

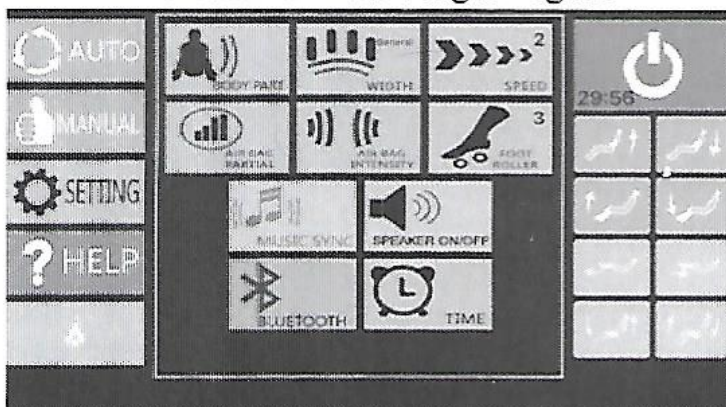

The connection is settled

# Troubleshooting

Failure	Possible cause	Processing method
Can not work after supplied power	Didn't turn on the power switch	Turn on the switch
	Didn't choose massage program	Choose a massage program
	Bad connection between plug and socket	Connect again
	Power cord or plug damaged	Replace the power cord
	The fuse burned up	Replace the fuse
	A fault in the controlling circuit	Contact with the maintenance department of supplier
Working with tap-tap-tap or hum sounds	Sounds from air pump, motor or other mechanical parts	Normal phenomenon
Different hight for the massage rollers	Rollers under alternately work	Normal phenomenon
Abnormal sounds suddenly occurred while working	If after long time works	Cut down the power and check after 30 minutes
	Cause from long time work	Contact with the maintenance worker
Suddenly stopped working	If after long time works	Supply power again
	Auto programmed time is up	Cut down the power and use after 30 minutes
Can not recline	Obstracter there; work overloaded automatically stopped work for protecting machine	To move the obstracter; stop work and use after 30 minutes
Can not restore after relined	Problem on electromotion pole or plug-ing under bad connection	Contact with the maintenance worker
Control panel overheat seriously	Cause from long time work	Cut down the power and call the maintenance worker
Abnormal overheat from power wire and plug	Work overloadingly	Cut down the power and use after 30 minutes
	Causes from other resons	Cut down the power and call the maintenance worker



If problems all are not from above reasons, please stop power supply and contact with the distributor or factory for maintenance.



## Specifications

Model	Image Home Therapeutics
Performance parameter	
Massage Stroke Length(cm)	130
Rollers Space Between(cm)	4-18
Tap(cpm)	200-600
Pummel (cpm)	100-450
Knead&Tap(cpm)	10-90
Shiatsu (cpm)	180
Knead (cpm)	25-100
Calfrest Recline Angle(° )	0-100
Backrest Recline Angle(° )	128-160
Calfrest stretch Length (cm)	0-25

Model	
Technical Spec	
Dimension of main box. (cm)	L152*W68*H87
Dimension of armrest box.(cm)	L165*W54*H73
Dimension of the leg structure(cm)	L60*W54*H55
Net weight of main box.(kgs)	81
Gross weight of main box.(kgs)	98
Net weight of armrest(kgs)	29.5
Gross weight of armrest(kgs)	47
Net weight of leg structure(kgs)	23.5
Gross weight of leg structure(kgs)	28

Model	
Specifications	
Rated Voltage	AC100-120V AC200-240V
Rated Frequency	50-60Hz
Power Consumption	300W
Safety Standards	Type 1